



MELNIK
RESOURCES LTD.

Lean Carts: Representative Selection



164-7579-1-1

164-7579-1-1:

Hose Part Cart

Parts carts for difficult to handle hoses – can be forklift handled as well as pushed by operator. Contains hoses within the foot-print of the cart to prevent damage. The cart enables the operator to load the cart and present materials without snagging and entanglement issues.



164-7579-1-1



164-4508-1-1 Dolly Cart

Dolly carts – that accept bins, pallets, trays, boxes etc... Designed to fit standard size 45x48 or custom sizes on request. Available for all industry standard tray dimensions as well. These units can be towed in series through the factory. Easy to push into position at line side and the hitch stores away for safety.

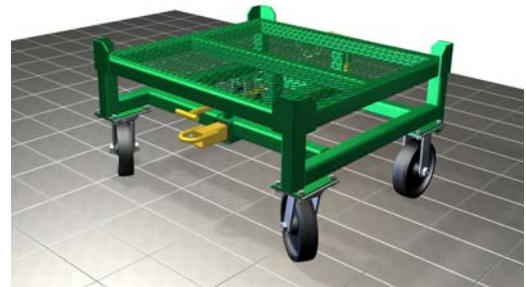

164-4508-1-1 Dolly Cart

Melnik Resources Ltd.

Lifting solutions from the ground up.

2467 Queen St.,
Box 144,
Mt. Brydges, Ontario
N0L 1W0

Phone: 519-264-2300
Fax: 519-264-2707
E-mail: sales@melnik.ca



Slide Rail Cart

Slide Rail Cart

Easy to handle cart with product protecting glide rails. Allows bulky/ cumbersome product to slide on and off cart with minimal effort. Special rail material protects expensive finishes.



102-7411-1-1

102-7411-1-1

Height adjustable cart for build operations. Can be powered by hand crank or cordless drill. End fixtures rotate the component to eliminate excess reaching or walking around the component for access. Easy to maneuver – addresses ergonomic positioning issues



102-7411-1-1



164-4509-1-1

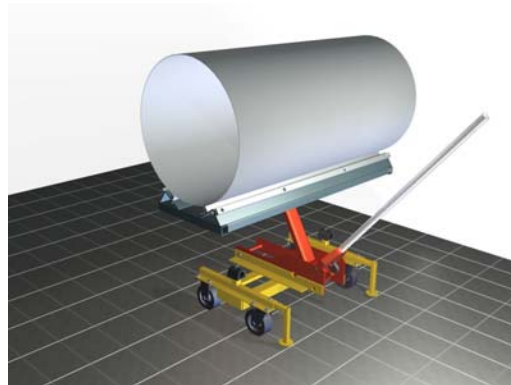

164-4509-1-1

164-4509-1-1

Hand pump and towable cart for lifting and positioning large tanks. Unit designed with stabilizing legs for operator safety. Fast lift action and easy to steer mechanism. Eliminates costly and cumbersome overhead rails and vacuum lift systems.

164-7503-1-1

Custom Parts Presentation Cart

Multiple adapters mount on centre post. Cart can be quickly reconfigured to accept different sizes of same components. Allows up to 40% more parts to fit onto carts. Units can be towed in series – to eliminate fork lift traffic. Has fork lift access from all 4 sides to load onto transport truck for shipping. Built with special floor locks to improve in transport truck safety. Capable of rotating within it's own foot print. Special fold down handles for operator—handling ergonomic and safety considerations (reduced push/pull effort and avoiding 'heel crush' when pulling).



164-7503-1-1



164-7503-1-1

115-7450-1-1



115-7450-1-1

Mobile assembly jig – capable of locking into floor track. Unique 'cow catcher' style caster guards to protect workers from foot crush. Height adjustable deck – raises large objects into position and assures accuracy of final assembly.



MELNIK
RESOURCES LTD.

2467 Queen St.,
Box 144,
Mt. Brydges, Ontario
N0L 1W0



MELNIK RESOURCES LTD.

Autodesk Inventor 3D software and **online collaboration** tools help to streamline information sharing and ensure clear communication of design and production information. The engineering team is able to incorporate customer design data into the models prior to prototyping - **minimizing cost and improving efficiency.**

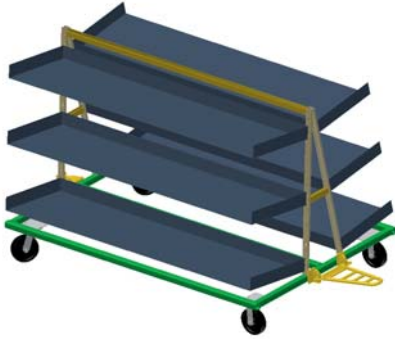

Tugger Cart

Tugger Cart

Carts to be towed in series behind tug motors.

Storable hitches for safety. Adjustable shelving - Cart quickly adapts to internal shipping box size changes. Shelves sloped to centre – prevents costly spill issues when cornering.



Tugger CART

164-7688-1-1



164-7688-1-1

Hinged tray carts– trays tilt out of the way to access compact storage and facilitate handling of multiple small components. Fold away pull handle to eliminate heel crush when pulling. Optional lock to integrate with scissor lift for ergonomic loading and unloading of parts.

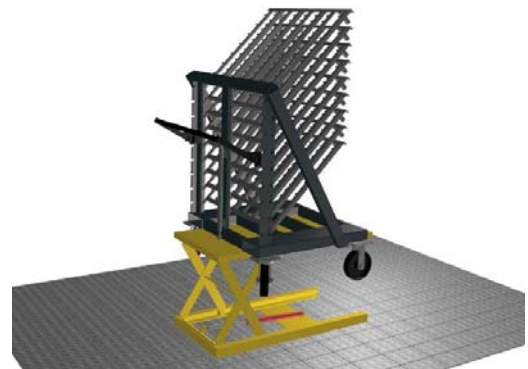

164-7688-1-1

Melnik Resources Ltd.

Lifting solutions from the ground up.

2467 Queen St.,
Box 144,
Mt. Brydges, Ontario
N0L 1W0

Phone: 519-264-2300
Fax: 519-264-2707
E-mail: sales@melnik.ca

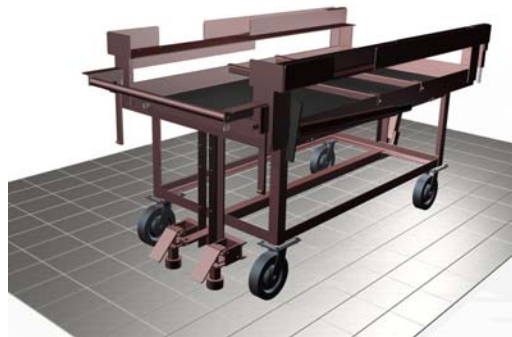

164-7425-1-1

164-7425-1-1

Heavy duty cart for sequencing cast components into assembly jigs. Special glide rails reduce operator efforts to slide components on and off cart into assembly jigs. Reinforced top rail section withstands the rigors of industrial erosion. Built with safety locks to prevent materials from sliding off top rails. Storage bins for smaller component handling. Floor lock downs are Heavy Duty for external shipping. Cart can be towed through factory, pushed with handle and/or picked and placed by forklift.